

Vertical Plateau Electric

thermrad^{t°}

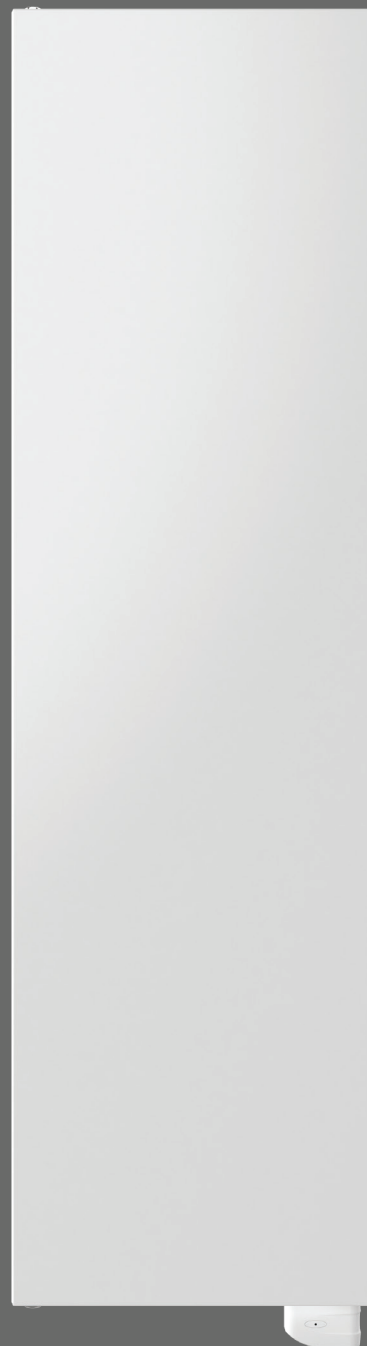



SAFETY INSTRUCTIONS

Please read these instructions carefully, in order to:

- ensure that your installation complies with applicable standards
- optimise your equipment's performance

We cannot be held liable for any damage arising as a result of incorrect installation or non-compliance with our instructions.

The installation of this device and any work conducted on its electrical components must be carried out by qualified personnel.

The electrical installation must comply with local and national applicable regulations.

WARNING: This device is not designed to bear the weight of a person, and no one should therefore climb onto it.
To avoid any risk of overheating, do not cover the appliance.

The radiator is designed to be wall-mounted, and must not be located directly under an electrical outlet. If the power cable is damaged, it must be replaced by us, our after-sales service or people of similar qualifications to avoid danger.

The heater contains a specific amount of fluid. Any repairs requiring the heater to be opened should be carried out by the manufacturer or by his maintenance representative. All leaks must be repaired by the manufacturer or his representative. All anomalies must be immediately corrected to ensure the safety of the installation and of the user. Should any problem arise, please contact our after-sales service.

Please keep away from children aged less than 3, unless they are under permanent supervision.

Children aged 3 to 8 are only permitted to turn the device on or off if the device has been placed or installed in a normal position, and if the children are supervised or have been taught how to use the device safely, and understand the potential dangers. Children aged 3 to 8 should not connect, set or clean the device, and should not perform maintenance tasks normally carried out by the user.

This device can be used by children aged 8 or more, and by persons whose physical, sensory or mental capacities are reduced, or who have no knowledge or experience of the device, if such persons are properly supervised, or if they have been instructed as to the safe use of the device, and if all potential risks have been properly understood. Children should not play with the device. Cleaning and maintenance work conducted by the user must not be carried out by unsupervised children.

WARNING : Attention should be particularly paid in the presence of children and vulnerable persons.

POSITIONING THE DEVICE

In the bathroom

This is a class II heater with an IPX4 protection rating and, as such, it can be installed in volume 2 or 3 of the bathroom (see figures 1a and 1b), provided that it is shielded from water splashes, that the radiator is out reach of persons in the bath or under the shower, and that it is plugged in a wall socket placed in volume 3. The battery-operated thermostat should be positioned in volume 3 and out of water splash range (IP20).

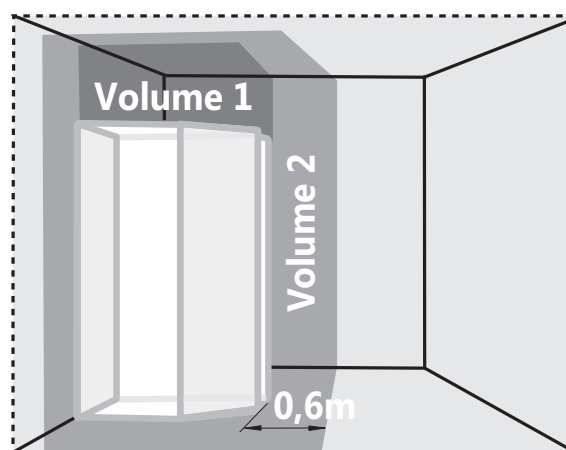
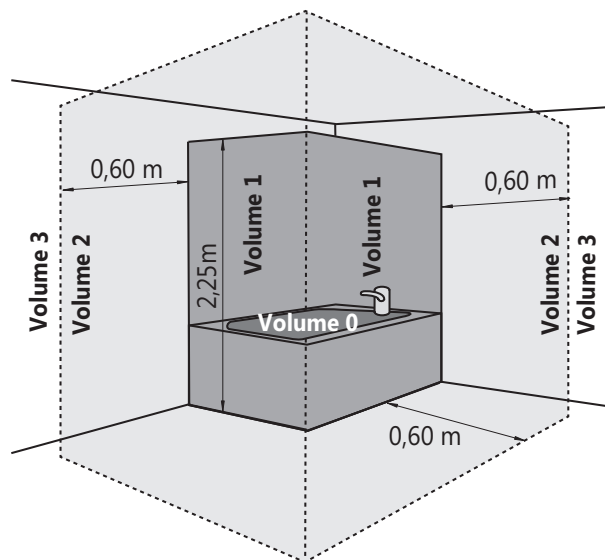

INSTALLING THE DEVICE

The radiator must be installed with the heating element vertical and the receiver in the lower section (figure 2a).

It is prohibited to install the device with the receiver in the upper section (figure 2b) or with the heating element horizontal (figure 2c).

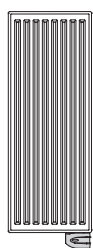

Fig. 2a

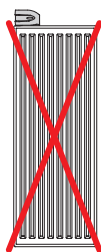

Fig. 2b



Fig. 2c

Electrical connection

As this appliance is fitted with a power plug, it is prohibited to install it in France.

When installed in a bathroom, it must be safeguarded with a differential switch of 30 mA.

The device is class II insulated and, therefore, it cannot be earthed. The device should be powered by a single-phase current of 220-240V ~50Hz.

The electrical plug must be accessible at all times.

In the event of a faulty controller, it should be replaced with an identical model. To find the right model, please contact your wholesaler. Replacing the control box with another model voids the guarantee and renders the device non-compliant with safety standards.

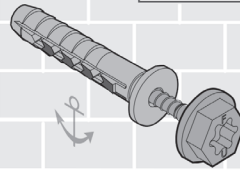
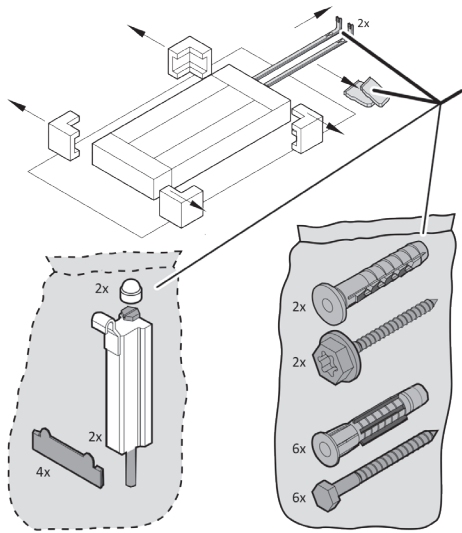

FISHER SXR 10:60 FUS



ETA-07/0121
(www.eota.eu)

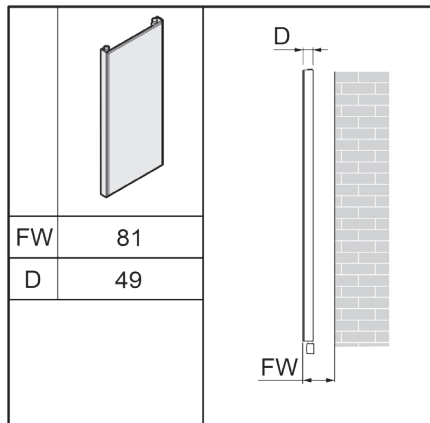
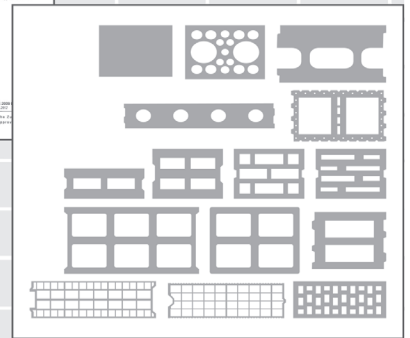

L	A
500	260
600	360
700	460

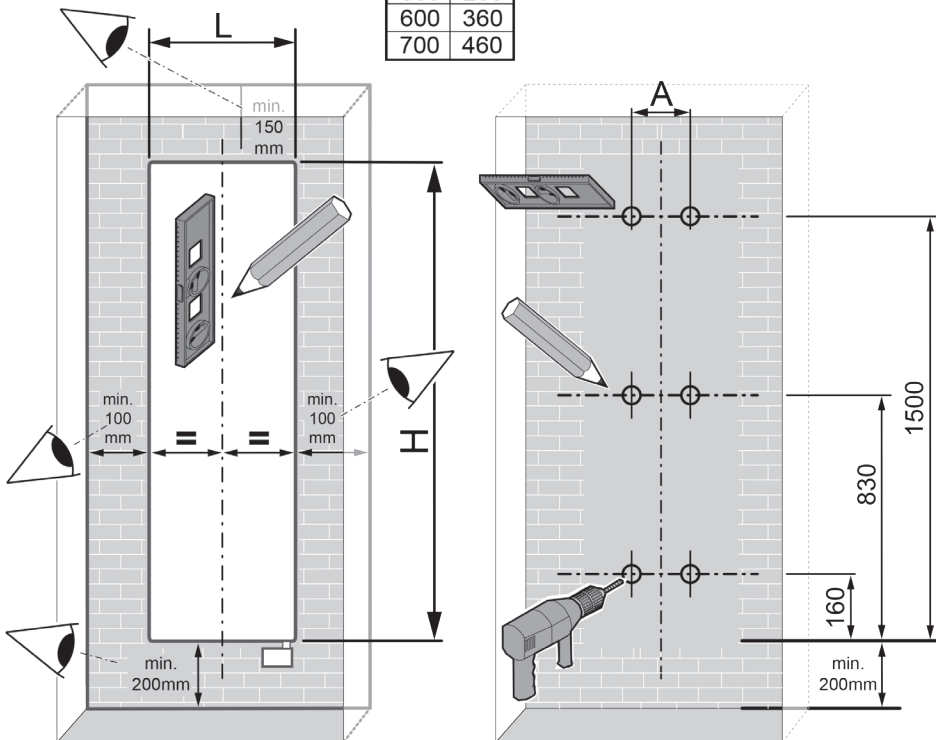

Geleive uitsluitend de bijgeleverde pluggen & schroeven te gebruiken in geschikte wanden, dit conform ETA-07/0121

Please use only the supplied plugs & screws in suitable walls, in compliance with ETA-07/0121

Bitte verwenden Sie ausschließlich die mitgelieferten Dübel & Schrauben in geeignete Wände, in Übereinstimmung mit ETA-07/0121

Veillez utiliser uniquement les chevilles et vis fournies, dans des murs convenables, en conformité avec ETA-07/0121

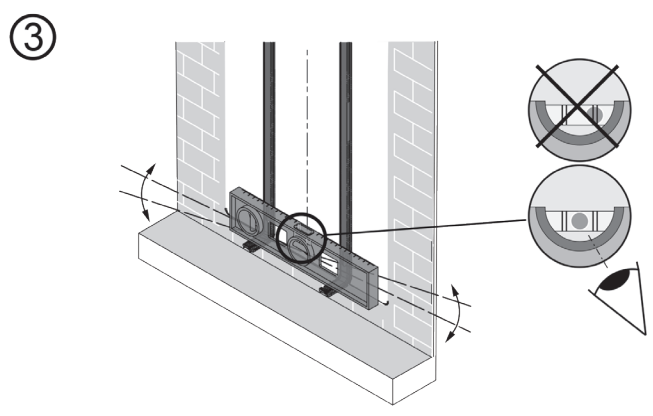
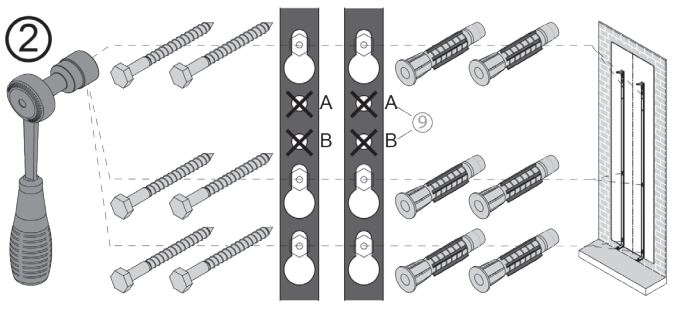
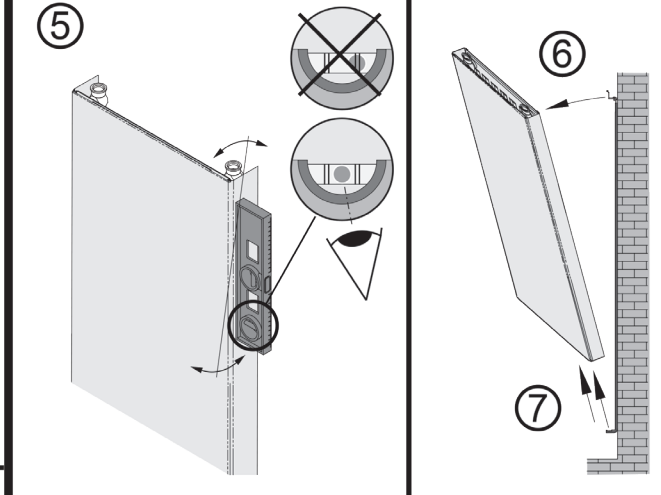
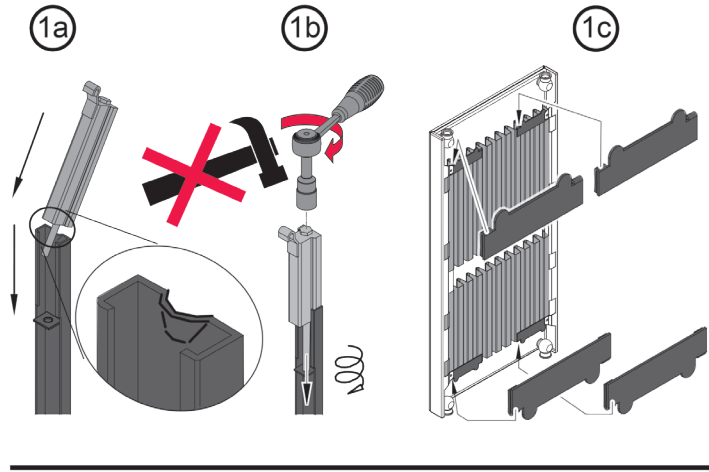

Indien gat A niet voldoet (zie muursterkte) gat B gebruiken.
 If hole A is unsuitable (see wall strength) use hole B.
 Bei ungeeignetem Bohrfloch A, Bohrfloch B verwenden. (siehe Wandstärke)
 Si trou A ne convient pas, (selon l'état du mur): utiliser trou B.

SW: 13mm
T40

$d_p: \downarrow$
 $\varnothing 10mm$

$t_{ef}: \downarrow$
Min. 50mm | Max. 10mm

$l: 60mm$

$t_d: \text{Min. } 75mm$

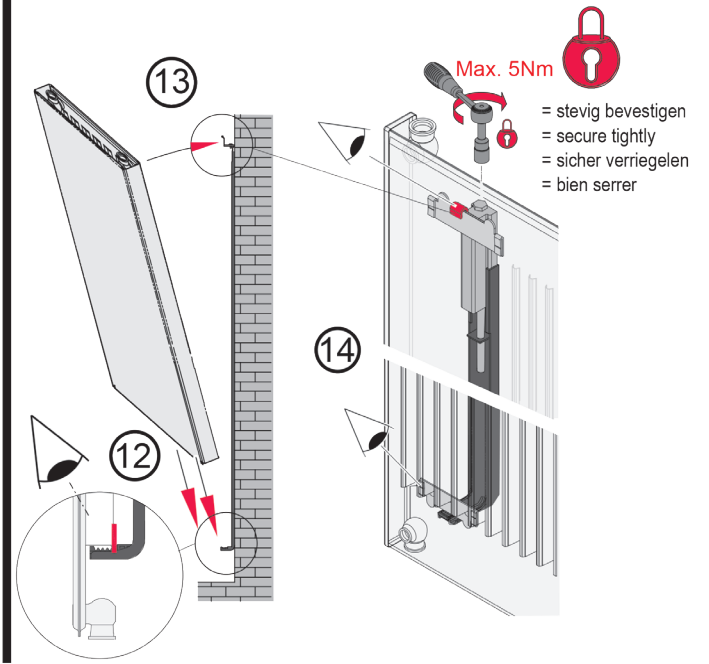
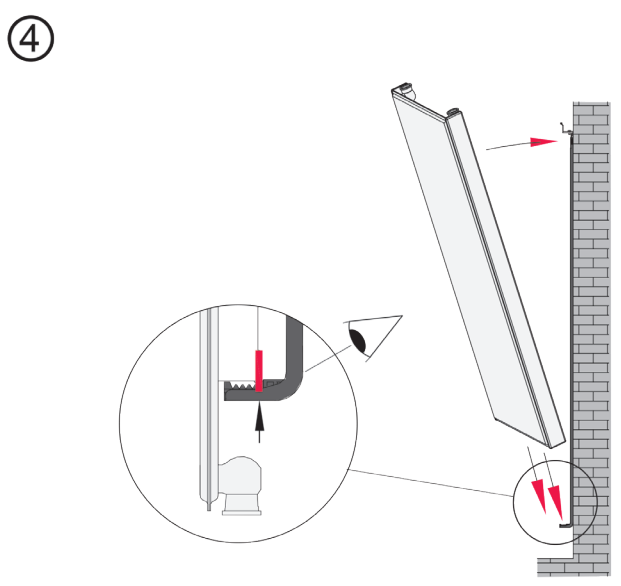

PACK CONTAINS

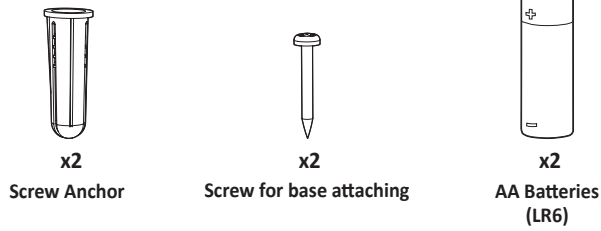

CONTROLS AND DISPLAY

• The keys

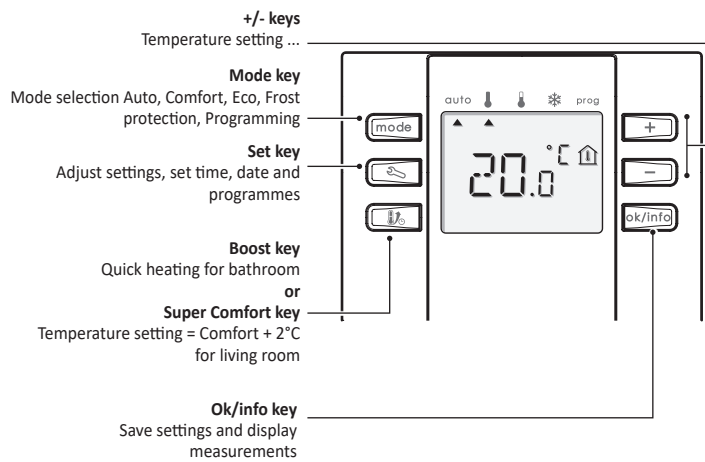

• The display

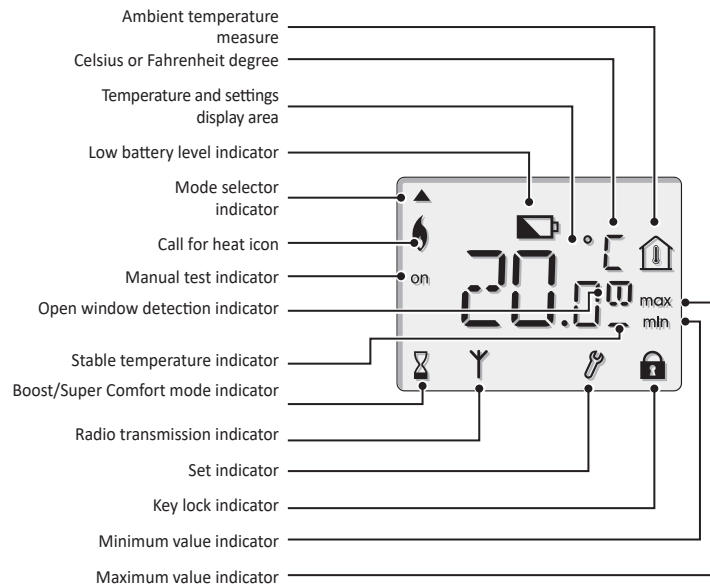



INSTALLATION

INSTALLING BATTERIES

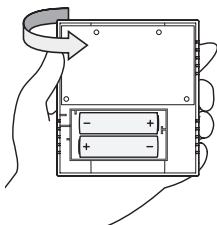
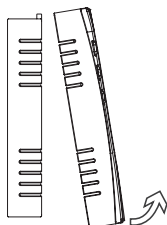
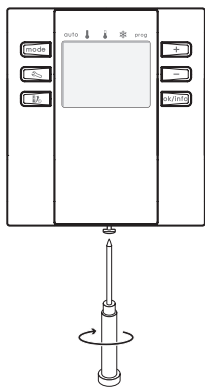
- 1- Then take out the screw under the device.
- 2- Remove the front cover.
- 3- Turn over the front side and insert the 2 supplied LR6 batteries. Note the correct polarity when inserting the batteries.



When the batteries must be changed, a low battery level indicator  lights up on the device.

 Remember to take used batteries to battery collection points so they can be recycled.

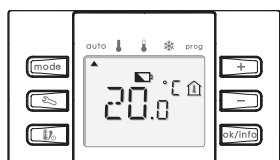

FIXING THE ROOM THERMOSTAT

Before attaching the device to the wall, check that the receiver is indeed within radio range of the room thermostat. After having removed the front cover of the room thermostat, proceed in the following order:

- 1- Secure the base with the two screws provided using the horizontal and vertical holes.
- 2- Put the front cover in place and tighten the screw under the device.

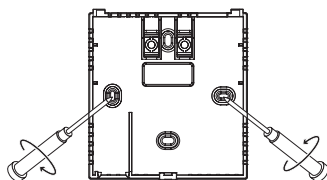

Recommended locations for your room thermostat:

To ensure that your room thermostat provides accurate readings and carries and controls effectively, it must be installed approximately 1.5 m above floor level on an inside wall, away from water sprays (IP20), direct sunshine and any other sources of heat or cold such as TVs, lamps, radiators, cold draughts, etc.

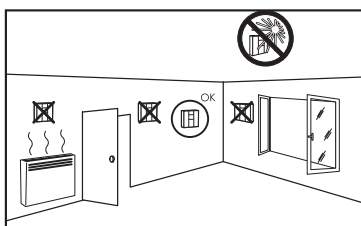

NB: In order to ensure proper operation of the product, ensure that the room thermostat is not positioned near to an area which could be affected by interference from another source.

E.g.: a mobile phone, a wireless transmitter or receiver, a TV screen, etc.

Important: The room thermostat measures the temperature of the place where it is installed. It does not take into account the temperature differences that may exist between different locations in the house if the temperature is not uniform.

QUICK SET UP

STAGE 1: CHOOSING THE APPLICATION

This room thermostat can be used in each room of your home. According to the use, needs are different:

- In a living room, i.e a dining room, a bedroom or a kitchen, this room thermostat enables you to weekly program, day by day, Comfort and Eco periods alternatively.
- In a bathroom, it enables to maintain a Comfort temperature and to weekly program, day by day, Boost periods i.e a temperature increase in the bathroom to heat or dry clothes or wet towels.

By default, the room thermostat is set to be used in a living room.

If the room thermostat is installed in a bathroom, the application type has to be modified before pairing with a receiver (refer to application type selection page 6)

STAGE 2: PAIRING THE ROOM THERMOSTAT TRANSMITTER WITH A RECEIVER

Pairing with a room thermostat

- 1- On the receiver, press and hold down the Memo button for about 5 seconds until the light flashes. If you make a mistake, press and hold down the button again for about 5 seconds to stop the procedure.

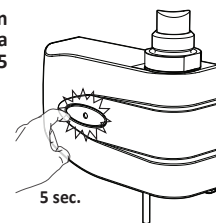

- 2- On the room thermostat, press the  button and hold it down for 3 seconds to carry out pairing. MEMO will be displayed.

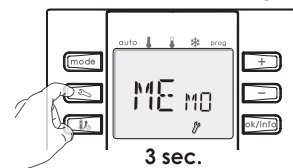

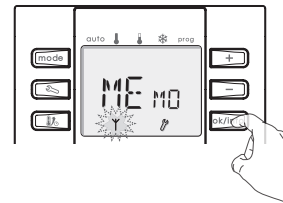

- 3- Press . The room thermostat will then send a radiowave configuration message and the  icon will be displayed briefly.



- 4- When the receiver gets this message, the red light on the receiver switches off. A link between the room thermostat and the receiver has been created successfully.

• Check the radio pairing

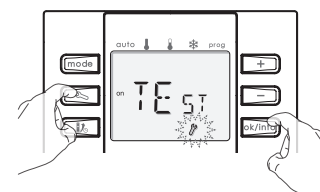

Before proceed to the check, be sure than the thermostat and the receiver are at their definitive location (see fixing the room thermostat, refer to the receiver installation guide). If you want to check the connexion between the room thermostat and the receiver, proceed as follow:

- 1- To access the Test Mode, press  and  simultaneously. TEST appears.
- 2- Press the  button = the ON signal will be sent out.



Wait on a few seconds than the receiver get the radio signal.

Press the  button = the OFF signal is sent out.

- 3- To exit the Test Mode, press  or  briefly.

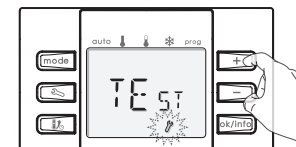

• Unpair the thermostat

Press and hold the receiver button for 10 seconds without releasing it: the automatic mode sequence which then takes place is described below:

- After 4 seconds, the LED light starts to flash, the pairing with the thermostat starts up.

- After 8 seconds, the LED light flashes faster, the receiver deletes pairing with the thermostat.

- After 10 seconds, the LED light goes off and the contact goes back to the at rest (or quiescent) status and the receiver will no longer recognise the thermostat.

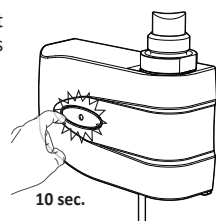

OPERATING

OPERATION MODE OVERVIEW AND SELECTION

Select the required mode by pressing **[mode]**.

Mode description	Display
<ul style="list-style-type: none"> • Auto mode In a living room (excluding bathroom) the room thermostat will change automatically from the Comfort mode to the Eco mode according to the established programming (refer to programmes overview page 4). In a bathroom: the room thermostat will change automatically from the Comfort mode to the Boost according to the established programming (refer to modifications of programmes page 4). 	
<ul style="list-style-type: none"> • Comfort mode The room thermostat will operate 24 hours a day to achieve the temperature which has been set (e.g. 20°C). Adjustable from 10°C to 30°C. Select this mode when you are in the room. 	
<ul style="list-style-type: none"> • Eco mode The room thermostat will operate 24 hours a day to achieve the temperature which has been set (by default 18°C). Adjustable from Comfort-1 to Comfort -5. Select this mode for short-term absences. 	
<ul style="list-style-type: none"> • Frost protection mode The room thermostat will operate 24 hours a day to achieve the temperature which has been set (by default 7°C). Adjustable from 5°C to 15°C. Select this mode when you will be away from your home for a long time (more than 5 days). 	

Important: The room thermostat measures the temperature of the place where it is installed. It does not take into account the temperature differences that may exist between different locations in the house if the temperature is not uniform.

SETTING THE SETPOINT TEMPERATURE

Select the mode you want to set the setpoint temperature by pressing **[mode]**.

You can set the setpoint temperature for the Comfort, Eco and Frost protection modes.

- 1- With the **[mode]** button, move the cursor under the desired mode.
- 2- Set the setpoint temperature by pressing **[+]** or **[-]**. Save by pressing **[ok/info]**.

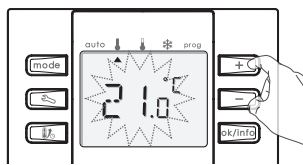

TEMPORARY TEMPERATURE CHANGE

From the Auto mode, using the **[+]** or **[-]** buttons, set the temperature, save by pressing **[ok/info]**.

This change will be automatically cancelled at the next change of programme or transition to 0:00.

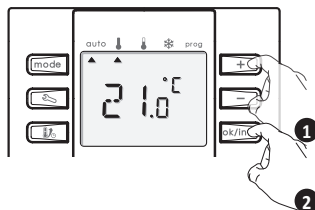

VIEWING THE SETPOINT TEMPERATURE

Your room thermostat displays the temperature in the room all the time but you can view at any time the setpoint temperature of the current running mode.

- 1- Press **[ok/info]** to view the temperature you have set on your room thermostat.

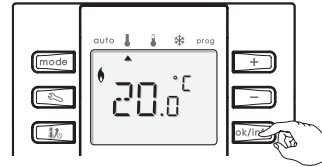

- 2- Press **[ok/info]** twice or wait few seconds to return to the ambient temperature measured:

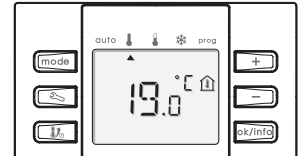

Note: if no buttons are pressed, the room thermostat will automatically return to active mode after few seconds.

SUPER COMFORT FEATURE OR MANUAL BOOST

A] In a living room

• Manual Super Comfort activation

This feature allows you to temporary increase the temperature up to 2°C compared to the setting temperature. The temperature increases during 60 minutes by default adjustable from 20 minutes to 2 hours in increments of 10 minutes.

To activate this feature, proceed as follow:

- 1- From the Auto, Comfort, Eco or Frost protection mode, press the **[boost]** button.
- 2- If needed, adjust at any time the duration by pressing **[+]** or **[-]**.

This modification will be saved and effective for the next Super Comfort activations.

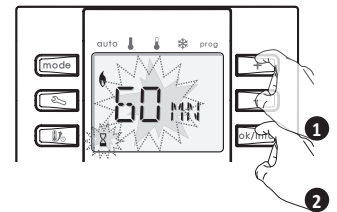

- 3- Save by pressing **[ok/info]**.

2nd press on **[boost]** or **[mode]**: Cancellation of super comfort mode.

Note: to view the set temperature, press **[ok/info]**.

B] In a bathroom

• Manual Boost activation

When in any operating mode, the **[boost]** button enables you to quickly increase the temperature in the bathroom during a 30-minute period (this is the pre-set duration).

- **First push on [boost]**

The desired (setpoint) temperature goes up to the maximum value for 30 minutes.

X appears on the display.

Boost duration: The pre-set duration flashes for 1 minute. While this happens, you have the option of changing the boost period duration to any duration between 20 and 60 minutes, in increments of 10 minutes, by pressing **[+]** or **[-]**. This change will be saved and will be effective for the next Boost periods.

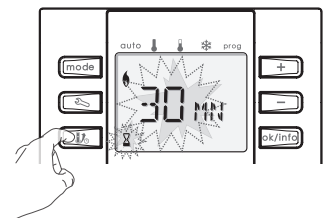

After 1 minute, the Boost period countdown begins and the time runs down, minute by minute.

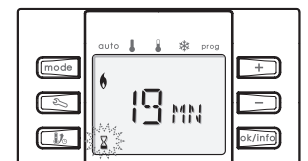

• Boost stop

Second push on **[boost]** or **[mode]**: the Boost feature will be cancelled.

DAILY AND WEEKLY PROGRAMMING

Before programming your thermostat, proceed to the time and day setting as described below.

• Setting the time and day

From the Auto, Comfort, Eco or Frost protection mode:

- 1- Press **[clock]**.

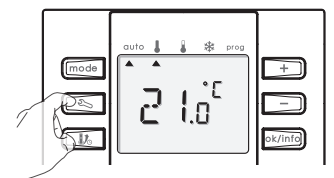

2- The two hour figures will flash. Select using **+** or **-**.

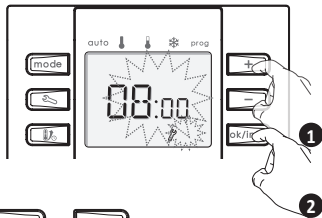

3- Save by pressing **ok/info** and set the minutes.

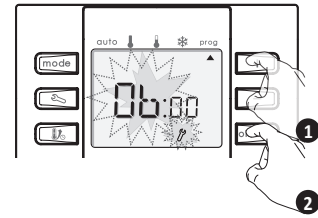

4- The two minute figures will flash. Select using **+** or **-**.

5- Press **ok/info** to save and set the day.

6- Select using **+** or **-**.

Correspondence of days			
MON	Monday	FRI	Friday
TUE	Tuesday	SAT	Saturday
WED	Wednesday	SUN	Sunday
THU	Thursday		

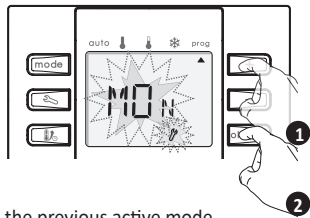

7- Press **ok/info** to save and automatically return to the previous active mode.

• **Viewing the time and day setting:**

Press **mode**: The hour appears, press successively **ok/info** to view the minutes then the day.

Press **mode** to exit and return to the current running mode.

• **View the programming**

1- Move the cursor under **Prog** by pressing **mode**.

2- Press **mode** then **ok/info** to view each programming parameter.

3- Exit and return to the Auto mode by pressing **mode**.

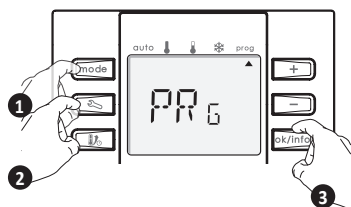

A] **In a living room**

• **Programmes overview:**

In this mode, you have the option of programming your room thermostat, by setting one of the six programmes on offer for each day of the week.

- Comfort: your room thermostat will operate in Comfort mode, 24 hours a day, as regards each day selected.
- Eco: The room thermostat will operate 24 hours a day in Eco mode.
- P1: your room thermostat will operate in Comfort mode from 06:00 to 22:00 (and in Eco mode from 22:00 to 06:00).
- P2: your room thermostat will operate in Comfort mode from 06:00 to 09:00 and from 16:00 to 22:00 (and in Eco mode from 09:00 to 16:00 and from 22:00 to 06:00).
- P3: your room thermostat will operate in Comfort mode from 06:00 to 08:00, from 12:00 to 14:00 and from 18:00 to 23:00 (and in Eco mode from 23:00 to 06:00, from 08:00 to 12:00 and from 14:00 to 18:00).
- P4: your room thermostat will operate in Comfort mode from 07:00 to 09:00, from 12:30 to 14:00 and from 19:00 to 23:00 (and in Eco mode from 23:00 to 07:00, from 09:00 to 12:30 and from 14:00 to 19:00).

Note : You can set the Comfort and Eco mode temperatures to the temperature you require (see Setting the setpoint temperature section page 3).

The room thermostat's default setting is Comfort mode for all the days of the week.

• **Potential modifications of programmes:**

If the default time schedules for the P1, P2, P3 and P4 programmes do not suit your routines, you can change them.

If you modify the time schedules for the P1, P2, P3 or P4 programmes, the schedules will be modified for all the days of the week for which P1, P2, P3 or P4 had been set.

To modify P1, P2, P3 or P4, proceed as follow:

1- **Access to the programming mode**

Move the cursor under **Prog** by pressing **mode**. Then press and hold the **mode** button down for more than **3 seconds**.

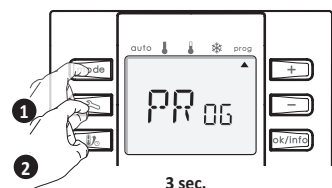

2- **Select the programme to modify**

Press **+** or **-** to select the programme you want to modify. Save by pressing **ok/info**.

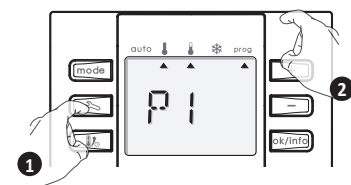

3- **Set the start time of the programmed Comfort period**

The Comfort period start time will flash. Press **+** or **-** to modify. Save by pressing **ok/info**.

Press **+** or **-** to modify the minutes of the Comfort period start time. Save by pressing **ok/info**.

4- **Set the start time of the programmed Eco period**

The Eco period start time will flash. Press **+** or **-** to modify. Save by pressing **ok/info**.

Press **+** or **-** to modify the minutes of the Eco period start time. Save by pressing **ok/info**.

For P2, P3 and P4 programmes, repeat steps 3 and 4 as often as necessary.

• **Allocation of programmes to the days of the week:**

By default, the Comfort mode is programmed 24 hours a day and 7 days a week.

To allocate a Comfort, Eco, P1, P2, P3 or P4 programme to each day of the week, proceed as follow:

1- **Access to the programming mode**

Move the cursor under **Prog** by pressing **mode** several times. Then press **mode**.

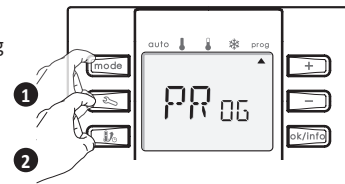

2- **Select the day to programme**

MON (monday) will flash, press **+** or **-** to choose a day of the week. Save by pressing **ok/info**.

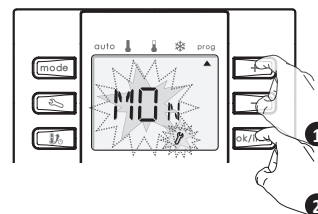

3- **Select the programme to affect**

MON (monday), select Conf, Eco, P1, P2, P3 or P4 to allocate it to the desired day. Save by pressing **ok/info**.

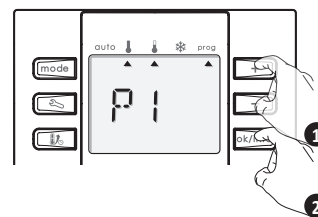

The next day, in our example **TUE** (Tuesday) will flash. Repeat the steps 2 to 4 until the desired number of days are programmed. To exit the Programming mode, press **mode** button. The thermostat returns automatically to the Auto mode.

To cancel the programming, see "Restoring factory settings" page 7.

• **Viewing programmes you have selected:**

See "View the programming" page 4.

B] **In a bathroom**

• **Boost period programming:**

In this mode, you can programme 1 or 2 boost periods per day, for the week or for few days. By default, no boost is programmed.

Important: Programmed boost duration.

The programmed boost duration is the same as the duration set for the manual boost, see chapter "Manual Boost" page 3.

1- **Access to the programming mode**

Position the arrow beside **Prog** by pressing **mode** several times. Then press **mode**.

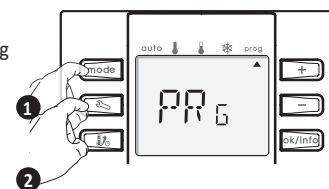

2- Select the day to programme,

MON (monday) will flash, press **+** or **-** to select a day of the week to program.

Save by pressing **ok/info**.

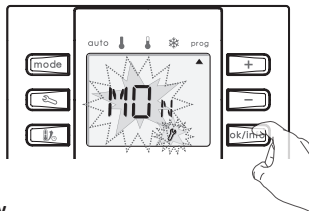

3- Select the number of programmed boost per day

You can program one or two Boost periods each day or none at all if you do not want there to be any Boost periods on a certain day.

OBo will flash, use **+** or **-** to choose the number of Boost periods to program):

- **0Bo** = no programmed Boost
- **1Bo** = one programmed Boost
- **2Bo** = two programmed Boost

Save by pressing **ok/info**.

4- Set the start time of the programmed boost period

- 1st programmed boost

If you have not chosen **OBo**, -- corresponding to the hour will flash, use **+** or **-** to choose the hour setting for the Boost period start time.

Save by pressing **ok/info**.

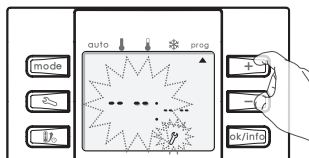

-- corresponding to the minutes will flash, use **+** or **-** to choose the minutes setting for the Boost period start time.

Save by pressing **ok/info**.



Note: pressing and holding down **+** or **-** for more than **two seconds** enables you to scroll through the numbers more quickly.

- 2nd programmed boost

If you have chosen two boost periods per day, --:-- displays. Repeat the previous step to set the 2nd boost start time.

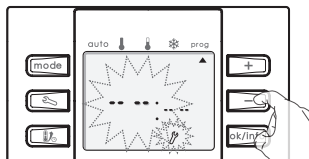

5- Programme the other days

You then need to program settings for the following day – for instance, **TUE** (tuesday) flashes if you have already programmed Monday.

Repeat steps 2 and 4 for each day until you have programmed the seven days of the week.

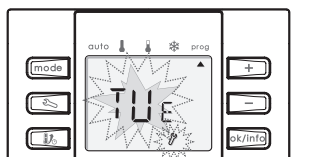

To exit the Programming mode, press **mode**, the room thermostat will automatically return to the Auto mode.

Note: When the programmed boost turns on, a cursor appears under Prog, under Auto and Comfort to indicate that the boost programming is on.

AUTOMATIC OPEN WINDOW DETECTION

• Important information about the open window detection

Important: the open window detection is sensitive to temperature variations. The thermostat will react to the window openings in accordance with different parameters: temperature setting, rise and fall of temperature in the room, outside temperature, its location in the room...

If the thermostat is located close to a front door, the detection may be disturbed by the air caused by opening door. Refer to the chapter "Fixing the room thermostat" page 2, indicating the best location to insure an optimum operation, otherwise, we recommend you to disable the automatic mode open window detection (refer to page 6).

• Overview

Lowering temperature cycle by setting frost protection during ventilation of a room by opened window. You can access the open window detection from the Auto, Comfort or Eco mode.

- **Automatic activation**, the lowering temperature cycle starts as soon as the thermostat detects a temperature change. An opened window, a door to the outside, can cause this temperature fall.

Note: The difference between the air from the inside and the outside must cause a significant temperature fall to be perceptible by the thermostat.

This temperature drop detection triggers the change to Frost Protection mode.

To disable the automatic open window detection refer to page 6.

• Frost protection digital meter

When the thermostat performs a lower temperature cycle due to opened window, a meter appears on the display to show the cycle time. The counter is automatically reset at the next time to Frost protection by opened window.



• Stop the Frost protection mode

By pressing one button, you stop the Frost protection mode.

Note: if a temperature rise is detected, the device may return to the previous mode (active mode before the open window detection).

CHILD SAFETY, KEYPAD LOCK/UNLOCK

• Keypad lock

To lock the keypad, press the **+** and **-** buttons and hold them for **3 seconds**. The padlock symbol appears on the display. The keypad is locked.

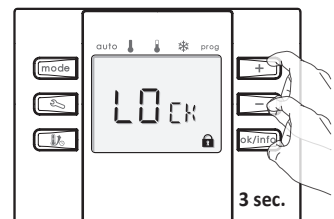

• Keypad unlock

To unlock the keypad, press the **+** and **-** buttons and hold them for 3 seconds again. The padlock symbol disappears on the display. The keypad is unlocked.

USER SETTINGS

From Auto, Comfort, Eco or Frost protection Mode, press **mode** and **-** simultaneously for **5 seconds** to go into the user settings.

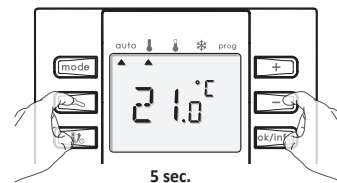

User settings sequence:

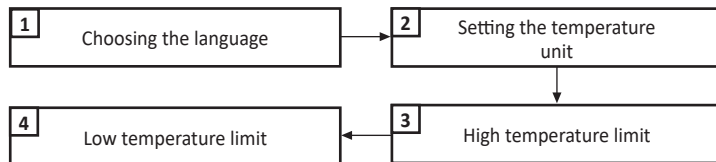

• Choosing the language

The pre-set user language for the room thermostat is French. You may choose from 4 different languages.

English	French	Italian	German
ENG	FRA	ITA	DEU

1- Select the desired language with **+** or **-**.

2- Save by pressing **ok/info**.

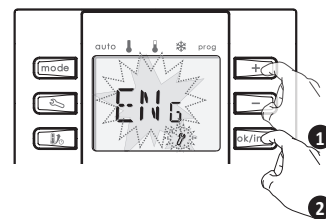

The following setting will be displayed:

• Setting the temperature unit

The pre-set temperature unit is Celsius degrees. It is possible to change it and to select Fahrenheit degrees.

1- Select the desired temperature unit with **+** or **-**.

2- Save by pressing **ok/info**.

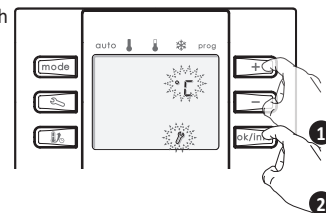

The following setting will be displayed:

• **Comfort setpoint temperature limit**

You can limit the setting temperature range by introducing a maximum and / or minimum setting, preventing unintentional changes in temperature.

• **High temperature limit**

Locking of the setting range using a maximum temperature increase, preventing the temperature from being set above that temperature.

The maximum setting is preset to 30°C. You can adjust from 15°C to 30°C by intervals of 1°C.

To change the maximum temperature setting, press **+** or **-** then save by pressing **ok/info**.

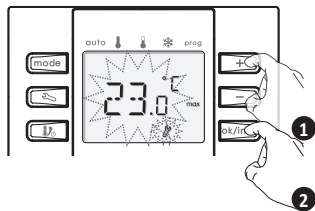

If you do not want to change it, press **ok/info**: the thermostat changes automatically to set the minimum setting.

• **Low temperature limit**

Locking of the setting range using a minimum temperature stop, preventing the temperature from being set below that temperature.

The minimum setting is preset to 10°C. You can adjust from 10°C to 19°C by intervals of 1°C.

To change the minimum temperature setting, press **+** or **-**.

To save and exit User settings, press **ok/info**.

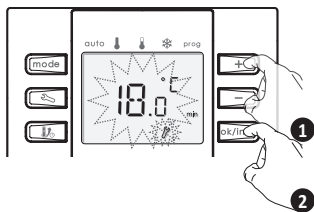

Tip: if the maximum and minimum desired (setpoint) temperatures are set to the same value, the desired temperature will be locked.

If you do not want to change it, press **ok/info**. The thermostat returns to the previous active mode.

INSTALLER SETTINGS

Access to Type of application and control type:

From Auto, Comfort, Eco or Frost protection Mode, press **mode** and **+** simultaneously for **5 seconds** to go into the Installer settings.

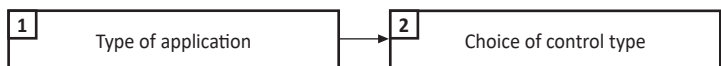

The following setting will be displayed:

• **Type of application**

This room thermostat can be used in each room of your home. According the use, needs are different:

- **In a living room**, i.e a dining room, a bedroom or a kitchen, this room thermostat enables you to weekly program, day by day, Comfort and Eco periods alternatively.
- **In a bathroom**, it enables to maintain a Comfort temperature and to weekly program, day by day, Boost periods i.e a temperature increase in the bathroom to heat or dry clothes or wet towels.

To modify the type of application, From Auto, Comfort, Eco or Frost protection Modes, press **mode** and **+** simultaneously for **5 seconds**.

1- Press **+** or **-** to select the type of application.

STD	Living room
BST	Bathroom

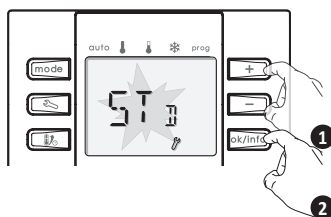

2- Save by pressing **ok/info**.

If **BST** is selected, the control type ON/OFF appears. Press **ok/info** again to save and exit setting mode.

If **STD** is selected, the next setting Choice of control type appears.

• **Choice of control type:**

When **STD** is selected as type of application, different types of controls are available. According to the kind of heating device or to the heating system controlled by the room thermostat, different types of controls can be used:

- **PID (TPI)** = high accurate control mode (Time Proportional & Integral) specially adapted to heating systems with medium or high inertia (inertia radiators, electric or hydraulic under floor heating systems).
- **ON/OFF** = standard control mode adapted to low inertia heating systems (e.g. bathroom towel rails, radiant heaters, blowers).
- **PIE** = cannot be used in these applications with standard receivers, a special receiver is needed.

To set the control type, proceed as follow:

1- Press **+** or **-** to select the control type.

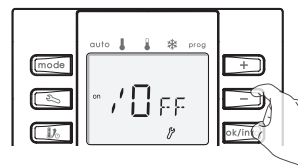

Note: the PIE mode cannot be used in these applications with standard receivers, a special receiver is needed.

2- Save by pressing **ok/info** and exit the setting mode.

Important: Each time you change the control mode, you have to pair the room thermostat with the receiver in order to send the new control mode and the corresponding information to the receiver.

• **Activation/ deactivation of the open window detection**

1- From Auto, Comfort, Eco or Frost protection modes, press simultaneously **mode** and **-** to enter setting mode.

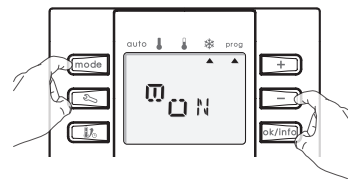

2- Press **+** or **-**.

- ON = Open window detection enabled
- OFF = Open window detection disabled

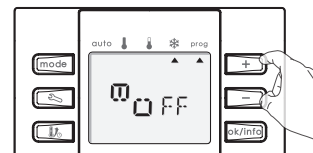

3- Press **ok/info** to save and exit the setting mode.

EXPERTS SETTINGS

From Auto, Comfort, Eco or Frost protection Mode, press **mode** and **mode** simultaneously for **5 seconds** to go into the Experts settings.

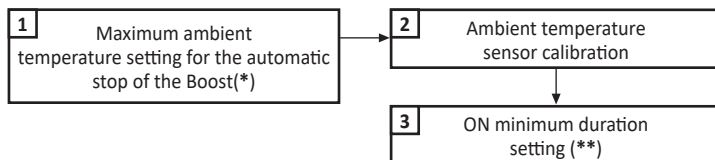

(*) If the ON/OFF mode and BST are selected.

(**) If the ON/OFF mode is selected. (See choice of the control type page 6)

• **Maximum ambient temperature setting for the automatic stop of the Boost:**

When the boost is on, the device must heat the room until a temperature limit: The maximum ambient temperature. When the limit is reached, the boost stop automatically. It's preset to 30°C, you can vary it from 20°C to 30°C by interval of 1°C. To modify it, proceed as specified as below:

1- Press or .

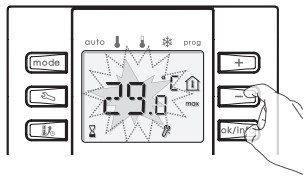

2- Save by pressing .

The following setting will be displayed.

Important: This operation is reserved for professional installers only; any wrong changes would result in control anomalies.

• Ambient temperature sensor calibration

In which cases? If the temperature measured in a room (measured by a reliable thermometer) is different of at least 1 or 2°C compared to the setpoint temperature of the room thermostat.

The calibration adjusts the temperature measured by the ambient temperature sensor to compensate for a deviation from + 3°C to - 3°C by increments of 0.1°C.

IMPORTANT: Before carrying out the calibration it is recommended to wait for 4h after a setpoint temperature modification to insure that the ambient temperature is stabilized.

To modify the measured temperature correction value, proceed as follow:

1- The display indicates to you the measured temperature correction value (which is 0 by default).

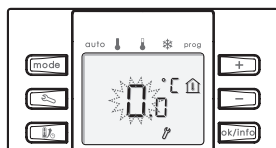

2- There are two possibilities:

2.1- If the room temperature difference is negative, example:

Setpoint temperature (what you want) = 20°C.

Ambient temperature (what you read on a reliable thermometer)= 19,5°C.

Difference measured = - 0,5°C.

Decrease the temperature measured by the ambient temperature sensor by 0.5°C by pressing .

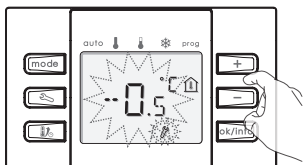

2.2- If the room temperature difference is positive, example:

Setpoint temperature (what you want) = 19°C.

Ambient temperature (what you read on a reliable thermometer)= 20°C.

Difference measured = +1°C.

Increase the temperature measured by the ambient temperature sensor by 1°C by pressing .

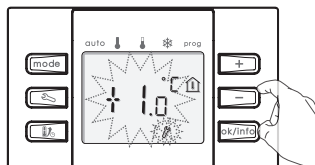

3- Press to save the new value and to return to the Auto mode.

If the ON/OFF control mode is used, the following setting will be displayed.

Note: In case of doubt on the modifications carried out, if you want to reset the device to the default factory settings, follow instructions "Restore to factory settings" (refer to page 7).

• ON minimum duration setting

This setting enables you to avoid unintentional triggerings and optimize the lifetime of the integrated relay in the receiver.

E.g

- From 1 to 2 minutes for a low inertia system (a blower).
- 3 minutes for a medium inertia system (radiant panel heater).
- 5 minutes for a high inertia system (under floor heating system).

1- Press or (by default, the value is preset at 1 minute, you can adjust it from 1 minute to 5 minutes by intervals of 1 minute).

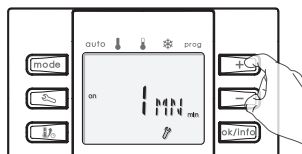

2- Press to save and to return to the previous active mode.

RESTORING FACTORY SETTINGS

- To restore factory settings and cancel programming press the , and buttons simultaneously and hold them down for at least 5 seconds.

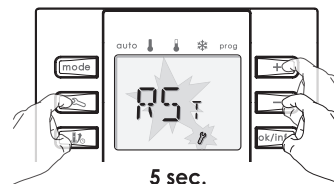

- Save by pressing .

The following settings will be reset:

Parameters	Factory settings
Operating	
Operation mode	Auto - Comfort
Comfort setting temperature	20°C
Eco setting temperature	18°C
Frost protection setting temperature	7°C
Hour and date	00:00 / Monday
Manual and programmed boost duration	30 minutes
Programmation type	Super Comfort programming
Programmed boost	None
Keypad lock	Disabled
User settings	
Language	French
Temperature unit	Degree Celsius
High setpoint temperature limit	30°C
Low setpoint temperature limit	10°C
Installer settings	
Type of application	STD (living room)
Control type	ON/OFF
Automatic open window detection	Enabled
Expert settings	
Maximum ambient temperature setting for the automatic stop of the Boost	30°C
Ambient temperature sensor calibration	0.0°C
ON minimum duration setting	1 minute

Important: after restoring factory settings you have to select again the application and pair again the room thermostat with the receiver (refer to page 2).

TROUBLESHOOTING

Batteries are used or inadapted.

- Replace the 2 batteries. Only use alkaline 1.5V LR6 batteries. Do not use rechargeable batteries.

There is no symbol inscription on the screen.

- Check the batteries.
- Replace the 2 batteries. Only use alkaline 1.5V LR6 batteries.

The heating does not come on or does not go off.

- Your room thermostat may have been set up close to a source of heat or on a cold wall – put it in a recommended location (see the "Installing" section on page 2 for these locations).
- Check that the time and the day have been correctly set on your programmable room thermostat (see "Setting the time and day" page 3).
- Remove the batteries for 5 seconds and reinsert them (see "Installing batteries" page 2).
- The radio link between the thermostat and the receiver is maybe lost (see "Thermostat/receiver radio transmission" page 8).
- No power supply to the receiver: check the position of the circuit breaker / power supply protection fuse in your fuse board.

The room temperature is lower than the required temperature.

- Check the active temperature setting and increase it if necessary (see "Setting the setpoint temperature" page 3).

The ambient temperature measured by a thermometer doesn't correspond to the setting temperature after several hours.

- An offset is always possible, you can refine the device setting (refer to page 7).

You want to change the operation mode but pressing has no effect:

- If the padlock symbol is displayed, the keypad lock is enabled.
- Unlock the keypad (See "Child safety: Keypad lock/unlock" page 5).

The room thermostat is in Auto mode, but the programming orders are not executed by the device:



- Check the Programming (see "Daily and weekly programming" page 3)
- If a Super Comfort programming is used, check the Boost duration (refer to the "Boost duration" section page 3).
- Check and replace the batteries (see "Installing batteries" page 2).
- The radio link between the thermostat and the receiver is maybe lost (see "Thermo-

stat/receiver radio transmission" page 8).

The super Comfort or Boost didn't start:

- Check the Super Comfort or Boost duration (refer to the "Boost duration" or "Super Comfort" section page 3).
- Check programming – refer to the "Viewing programmes" section (refer to page 4).
- Check that the time and the day have been correctly set on your programmable room thermostat – refer to the "Viewing day and time settings" section (refer to page 4).
- Check that the kind of application has been correctly set (refer to page 6).
- In Super comfort, several minutes can spend between Super Comfort activation and the heating on depending of the current operating status.

The Boost didn't start at the programmed time.

- Check the start time (see "Set the start time of the programmed boost period" page 5), If --:-- is displayed instead of the time, it indicates that no time is programmed for this starting period. Select the desired start time by  or .

The thermostat does not control properly.

- **Thermostat sensor may be influenced by a source of heat or cold** (see "Fixing the room thermostat" page 2).
- Check that the setting temperature has not been changed (see "Setting the setpoint temperature" page 3).

After temperature drop due to an opened window, the thermostat doesn't switch in frost protection mode :

- Check that the automatic open window detection mode is enabled (refer to page 6).
- Check the location of the thermostat (refer to page 2).
- Check if the difference between the room air temperature and the outside air temperature is significant.

The thermostat automatically switches in frost protection mode even windows are closed :

- Disable the automatic open window detection (refer to page 6).

The 2 horizontal lines below the automatic open window detection indicator frequently disappear from the screen :

- Check the location of the thermostat (refer to page 2).

Informations about the ambient temperature measurement:

- When the automatic open window detection is enabled, the thermostat measures and analyses permanently the room temperature where it's placed.
2 kinds of informatives indications can be seen on the screen:
 - **2 horizontal lines appear below the automatic open window detection indicator:**
The measured temperature is stable.
 - **The 2 lines disappear from the screen:** The measured temperature in the room is not stable a change of temperature in the room can triggered the automatic open window detection.
- If the temperature varies quite often, be sure than the thermostat is not disturbed by an external source (refer to page 2).



You made a mistake while setting the programming or the advanced settings:

- Just restore factory settings – see the "Restoring factory settings" paragraph (refer to page 7). This will erase any programmes that you would have implemented.
- Repeat the programming procedure (see "Daily and weekly programming" page 3).



Radio transmission:

Previously and before taking any action :

- Check that the thermostat is not affected by a source of heat (see "Installing section" page 2).
- Check that the thermostat is paired with the receiver (voir "check the radio pairing" page 2).

1- The receiver is not picking up the code sent by the emitter.

- Replace transmitter's batteries.

2- The receiver does not recognize transmitter's code.

- Pair the room thermostat transmitter with a receiver again (page 2).

3- The receiver or the transmitter is affected by interference:

- Move the emitter out of the affected area.
- Try to move away the receiver or the source of the interference

Loss of the radio link between the receiver and the thermostat.

- Repeat the radio pairing procedure on the thermostat, refer to page 2 and the receiver (refer to the installation and user guide).

If an anomaly is perceived on the receiver paired to the thermostat, refer to the installation and user guide of the receiver.

TECHNICAL SPECIFICATIONS

Power supply: 2 alkaline 1.5 V LR6 batteries.

Battery life: approx. 2 years.

Maximum range in the home: 15m to 20m is typical according to the environment.

Signal sending: every 10 minutes, maximum time-lag 1 minute after set-point temperature has been changed.

Maximum RF power transmitted: <5mW.

Environment:

- Operation temperature: from 0°C to +50°C.
- Manual temperature setting range: from +5°C to +30°C.
- Storage temperature: from -10°C to +50°C.
- Humidity: 80% to +25°C (without condensation).
- Protection rating: IP20.

N.B.: this room thermostat is one part of a complete radio system and will only work with the 230V AC receivers. Radio emitter, frequency 868.3 Mhz.

Can be used throughout Europe.

Manufactured by: IMHOTEP création FRANCE (contact@imhotepcreation.com)

EU declaration of conformity: We hereby declare under our sole responsibility that the products described in these instructions comply with the provisions of Directives and harmonized standards listed below:

- RED 2014/53/EU:
 - Article 3.1a (Safety): EN60730-1/ EN60730-2-9/ EN62311
 - Article 3.1b (EMC): ETSI EN 301489-1 V1.9.2 / ETSI EN301489-3 V2.1.1
 - Article 3.2 (RF): ETSI EN 300440 V2.1.1
- RoHS 2011/65/UE, amended by Directives 2015/863/UE & 2017/2102/UE : EN 50581



and are manufactured using processes that are certified ISO 9001 V2015.



The  on the product indicates that you must dispose of it at the end of its useful life at a special recycling point, in accordance with European Directive WEEE 2012/19/EU. If you are replacing it, you can also return it to the retailer from which you buy the replacement equipment. Thus, it is not ordinary household waste. Recycling products enables us to protect the environment and to use less natural resources.



MAINTENANCE TIPS

Maintenance operations must be done with the heater switched off. Therefore make sure that the appliance is off. In order to ensure your heater lasts, we recommend you use the following few tips:

- Use only mild cleaning agents when cleaning and wiping of the radiator (no abrasive or corrosive product).
- Use a dry cloth (without solvent) for the control unit.
- Any modification to the essential safety elements (such as the characteristics and the power of the heating resistance, the type and volume of the special fluid filling the electrical radiator) is not permitted.
- Unprofessional actions of such a kind immediately cancels the warranty.

Waste disposal

The symbol on the product label indicates that the product may not be handled as domestic waste, but must be sorted separately. When it reaches the end of its useful life, it shall be returned to a collection facility for electrical and electronic products. By returning the product, you will help to prevent possible negative effects on the environment and health to which the product can contribute if it is disposed of as ordinary domestic waste. For information about recycling and collection facilities, you should contact your local authority/municipality or refuse collection service or the business from which you purchased the product. Applicable to countries where this Directive has been adopted.

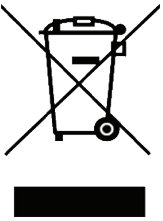

TECHNICAL DATA

Height (mm)	1800		
Length (mm)	500	600	700
Output (W)	1250	1500	1750
Article number	0978A181105	0978A181106	0978A181107

Voltage: 220-240V ~50Hz

Class II - IP44

Heating body in steel

Heating element with integrated thermal limiter and thermal fuse

Reference(s) of the model:	0978A181105, 0978A181106, 0978A181107				
Item	Symbol	Value	Unit	Item	Unit
Heat output				Type of heat output/room temperature control (select one)	
Nominal heat output	P _{nom}	1.25 / 1.50 / 1.75	kW	single stage heat output, no room temperature control	No
Minimum heat output (indicative)	P _{min}	1.25 / 1.50 / 1.75	kW	two or more manual stages, no room temperature control	No
Maximum heat output	P _{max,c}	1.25 / 1.50 / 1.75	kW	with mechanic thermostat room temperature control	No
Auxiliary electricity consumption				with electronic room temperature control	No
At nominal heat output	E _{lmax}	1.25 / 1.50 / 1.75	kW	with electronic room temperature control plus day timer	No
At minimum heat output	E _{lmin}	1.25 / 1.50 / 1.75	kW	with electronic room temperature control plus week timer	Yes
In stand-by mode	E _{ISB}	<0.001	kW	Other control options (multiple selections possible)	
				room temperature control, with presence detection	No
				room temperature control, with open window detection	Yes
				with distance control option	No
				with adaptive start control	No
				with working time limitation	No
				with black bulb sensor	No
Contact details:	Thermrad Toermalijnstraat 7 1812 RL Alkmaar - The Netherlands				

STANDARDS

CEM	Low voltage	RoHS
EN55014-1	EN60335-1	EN50581
EN55014-2	EN60335-2-30	
EN61000-3-2	EN62233	
EN61000-3-3		

